



SAMSUNG

COLOR TELEVISION RECEIVER

Chassis : S15A
Model: CK331FVR5X/NWT CK331FVR5X/BWT
CK331FVR5X/VWT CK501FVR5S/NWT

SERVICE *Manual*

COLOR TELEVISION RECEIVER



CONTENTS

1. Precautions
2. Specifications and IC Data
3. Disassembly and Reassembly
4. Alignment and Adjustment
5. Troubleshooting
6. Exploded View and Parts List
7. Electric Parts List
8. Block Diagram
9. PCB Layout Diagram
10. Wiring Diagram
11. Schematic Diagrams

11. Schematic Diagrams

11-1 ONECHIP

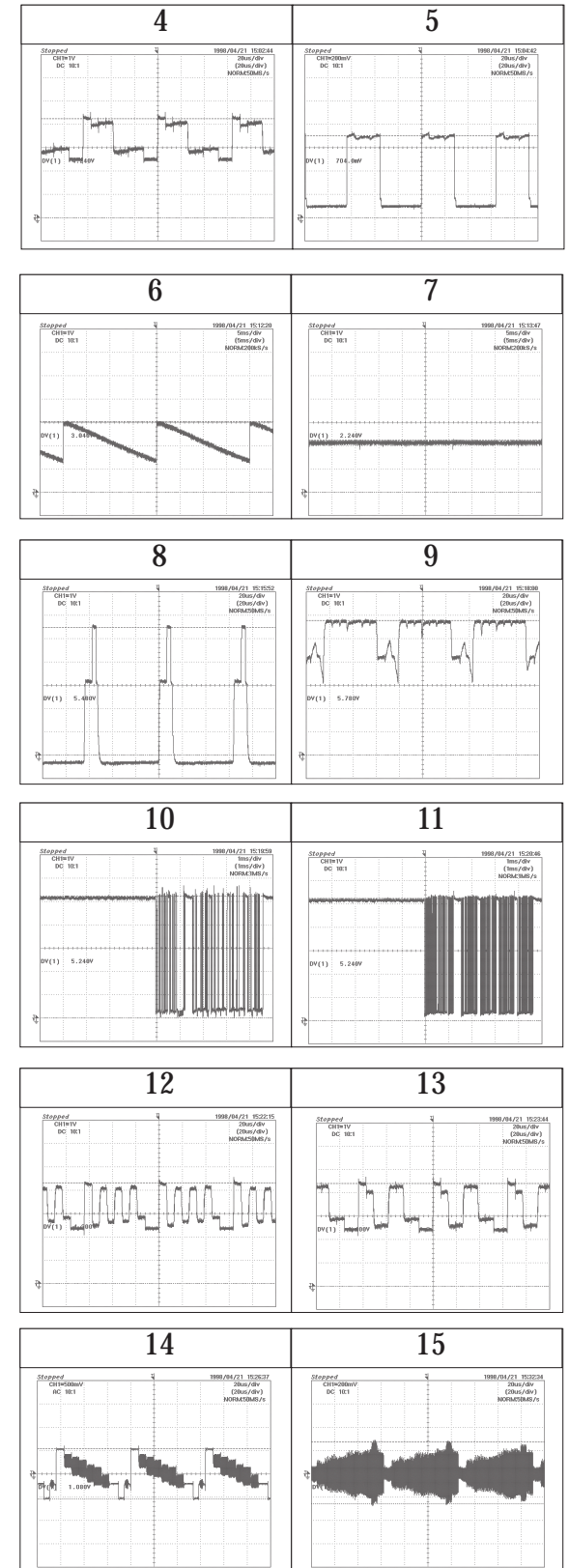
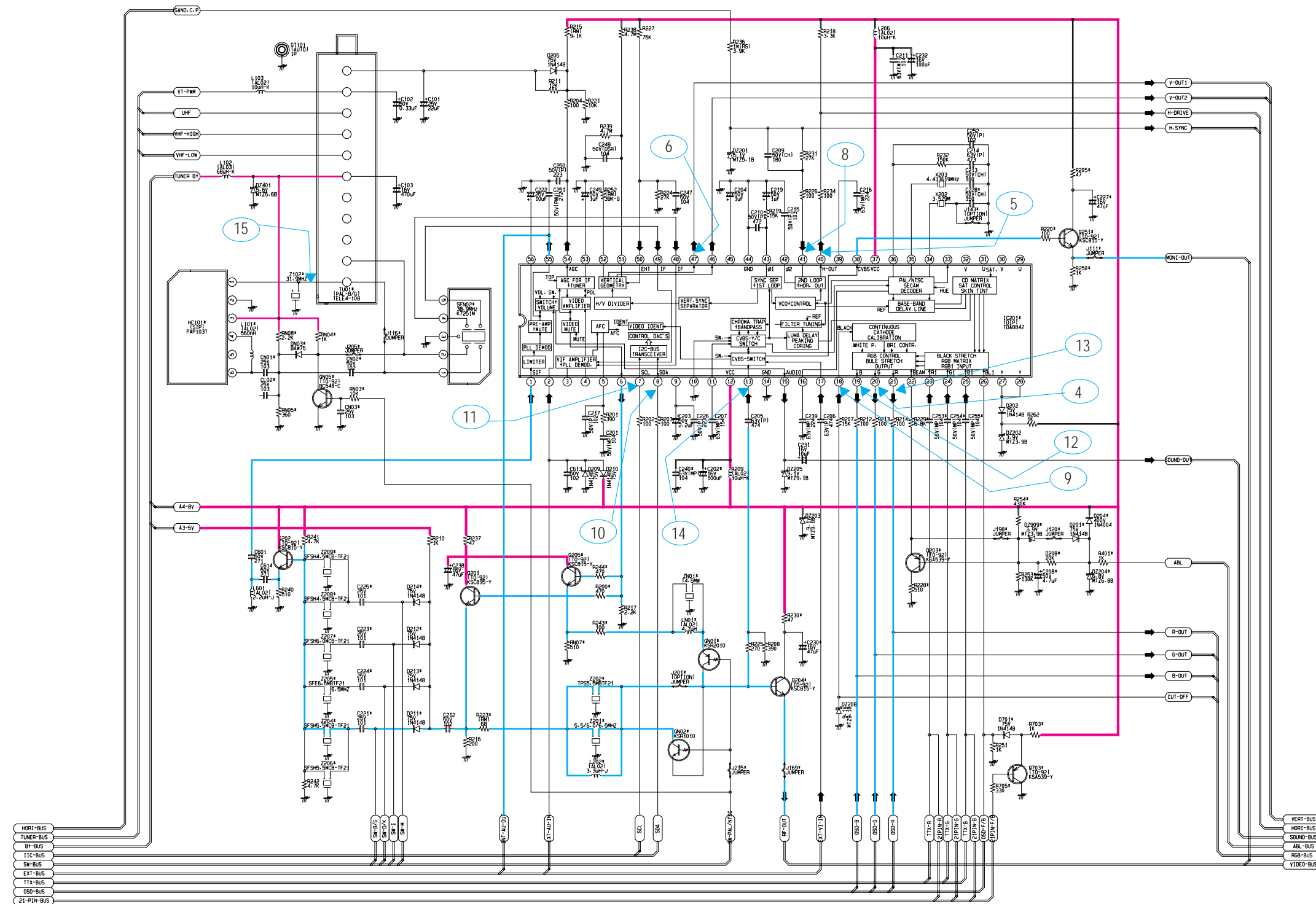

— : Power Line
 — : Signal Line

11-3 SOUND, EXT-A/V (Middle East / Asia)

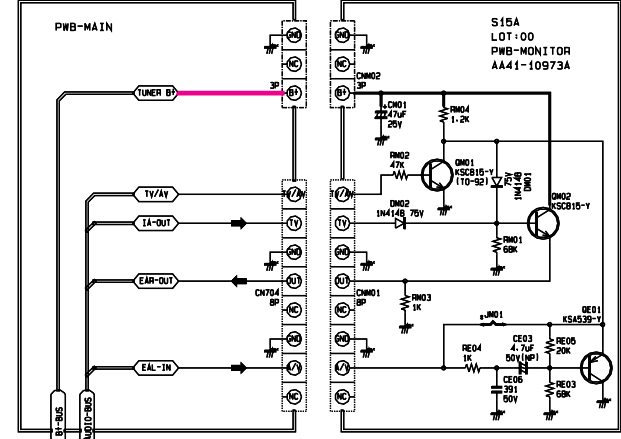
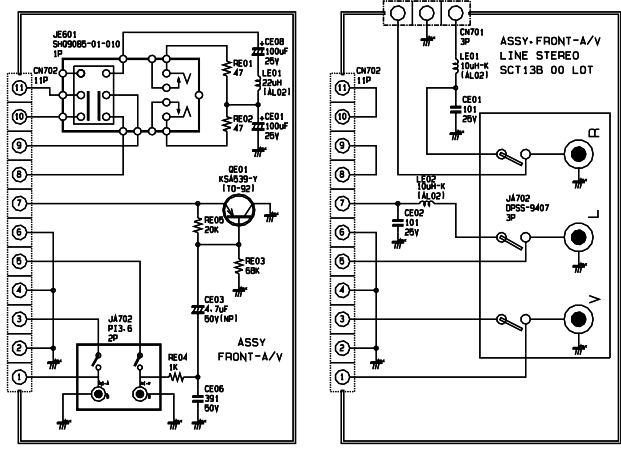
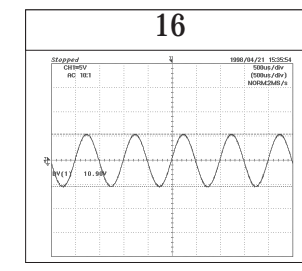
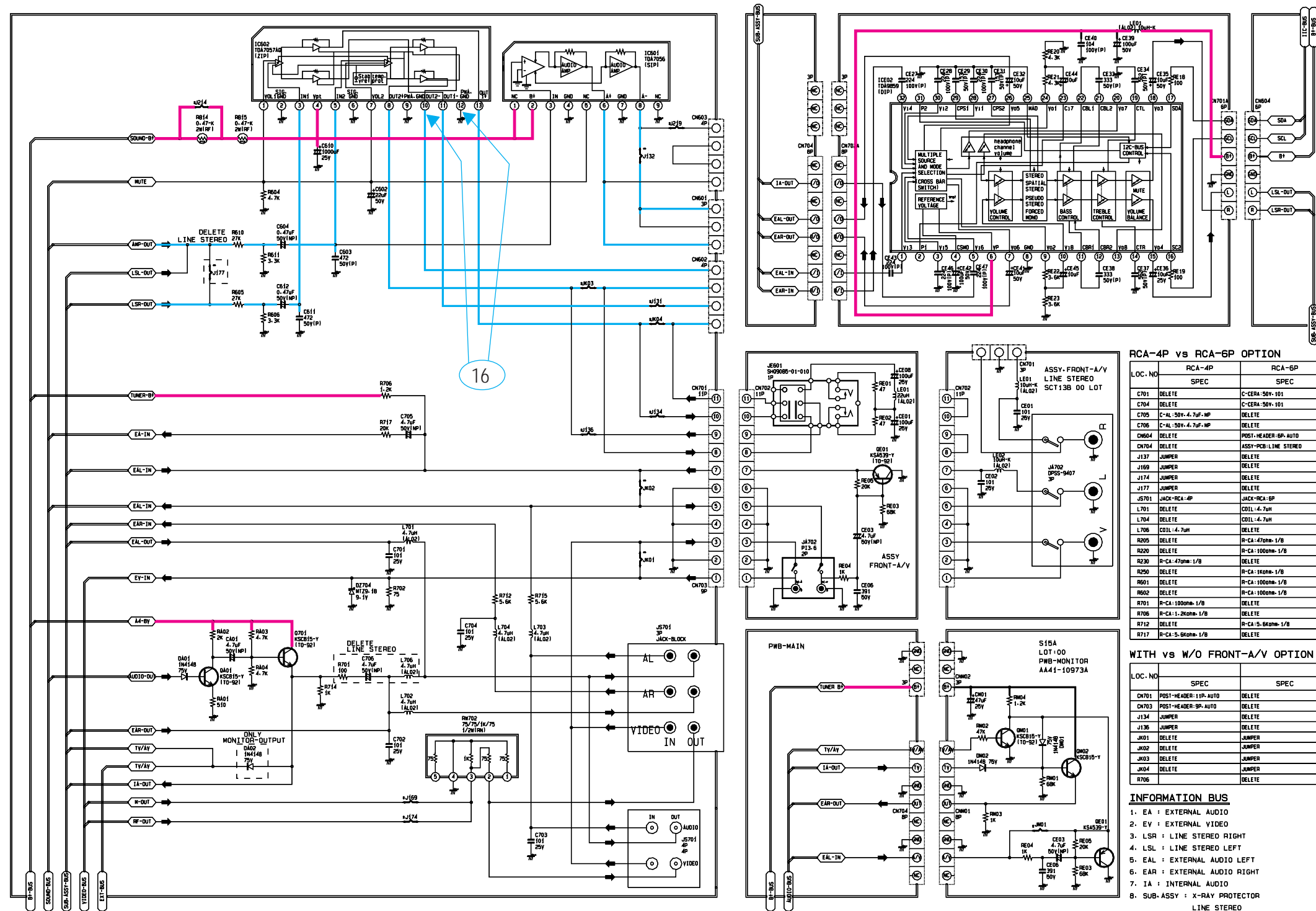

RCA-4P vs RCA-6P OPTION

LOC. NO	RCA-4P SPEC	RCA-6P SPEC
C701	DELETE	C-CERA-50V-101
C704	DELETE	C-CERA-50V-101
C705	C-AL-50V-4.7uF-HP	DELETE
C706	C-AL-50V-4.7uF-HP	DELETE
CH604	DELETE	POST-HEADER-SP-AUTO
CH704	DELETE	ASSY-PCB-LINE STEREO
J137	JUMPER	DELETE
J169	JUMPER	DELETE
J174	JUMPER	DELETE
J177	JUMPER	DELETE
J5701	JACK-RCA-4P	JACK-RCA-6P
L701	DELETE	COIL-4.7uH
L704	DELETE	COIL-4.7uH
L706	COIL-4.7uH	DELETE
R205	DELETE	R-CA-470ohm-1/8
R220	DELETE	R-CA-1000ohm-1/8
R230	R-CA-470ohm-1/8	DELETE
R250	DELETE	R-CA-1kohm-1/8
R601	DELETE	R-CA-1000ohm-1/8
R602	DELETE	R-CA-1000ohm-1/8
R701	R-CA-1000ohm-1/8	DELETE
R706	R-CA-1.2kohm-1/8	DELETE
R712	DELETE	R-CA-5.6kohm-1/8
R717	R-CA-5.6kohm-1/8	DELETE

WITH vs W/O FRONT-A/V OPTION

LOC. NO	SPEC	SPEC
CH701	POST-HEADER-1P-AUTO	DELETE
CH703	POST-HEADER-SP-AUTO	DELETE
J134	JUMPER	DELETE
J136	JUMPER	DELETE
J601	DELETE	JUMPER
J602	DELETE	JUMPER
J603	DELETE	JUMPER
J604	DELETE	JUMPER
R706	DELETE	DELETE

- INFORMATION BUS**
- 1. EA : EXTERNAL AUDIO
 - 2. EV : EXTERNAL VIDEO
 - 3. LSR : LINE STEREO RIGHT
 - 4. LSL : LINE STEREO LEFT
 - 5. EAL : EXTERNAL AUDIO LEFT
 - 6. EAR : EXTERNAL AUDIO RIGHT
 - 7. IA : INTERNAL AUDIO
 - 8. SUB-ASSY : X-RAY PROTECTOR LINE STEREO

Power Line
Signal Line

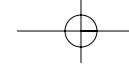

Schematic Diagrams

11-4 POWER / CRT / VERTICAL / HORIZONTAL

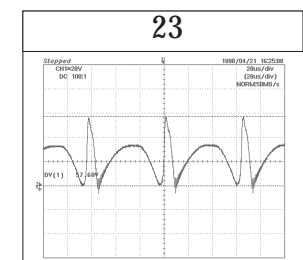
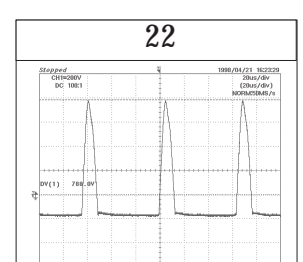
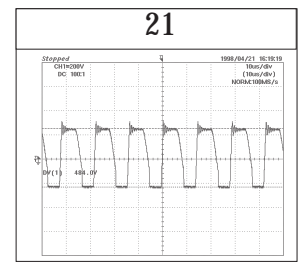
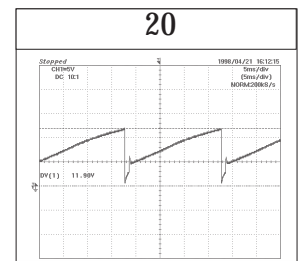
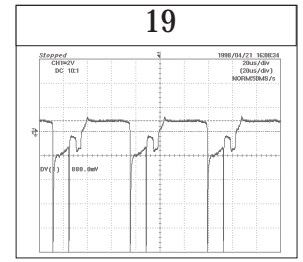
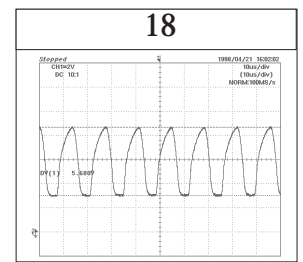
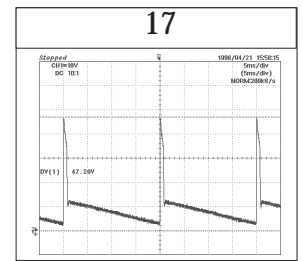
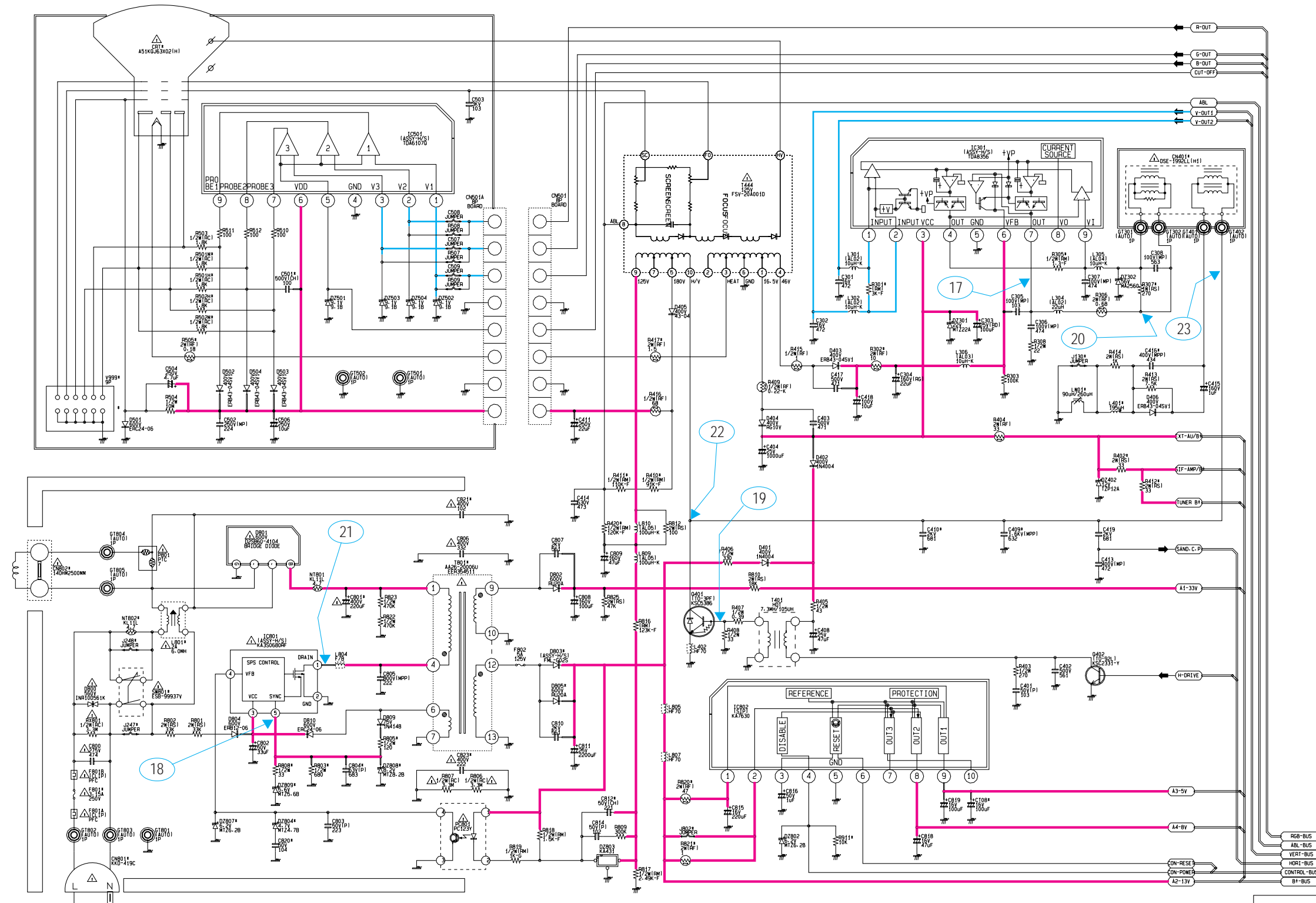

— : Power Line
 — : Signal Line

11-5 MICOM (TTX)

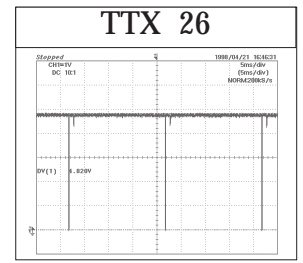
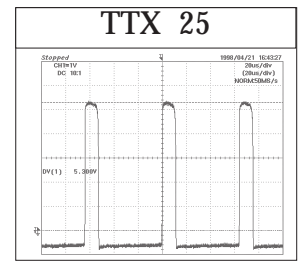
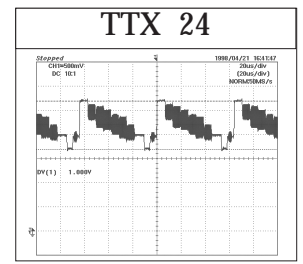
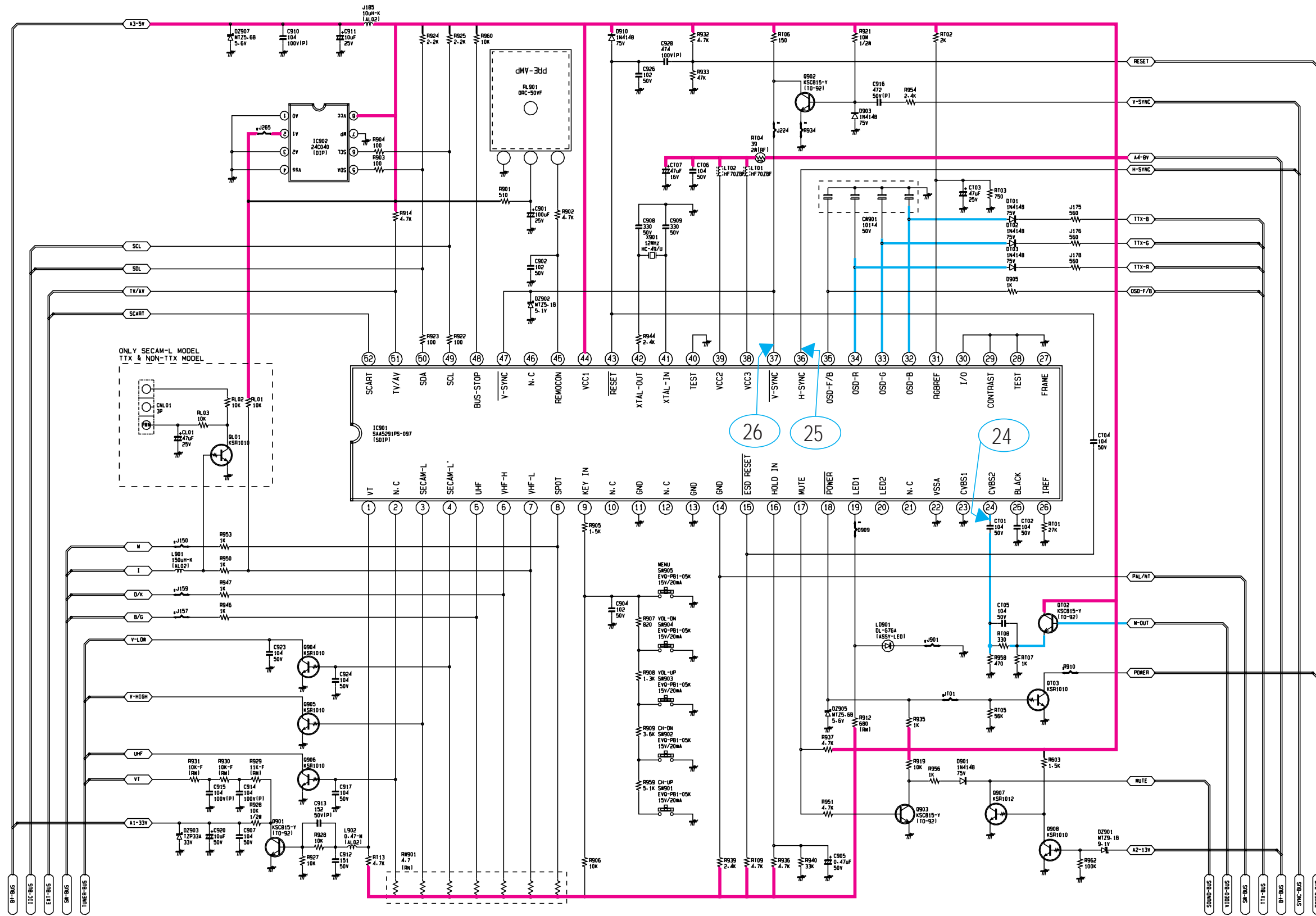

— : Power Line
 — : Signal Line

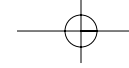

Schematic Diagrams

11-6 MICOM (NON-TTX)

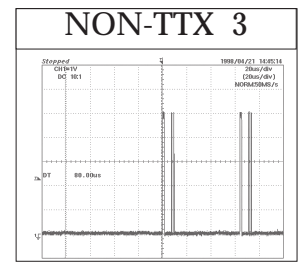
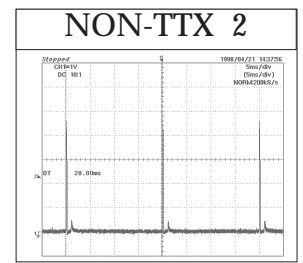
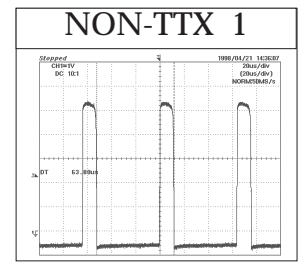
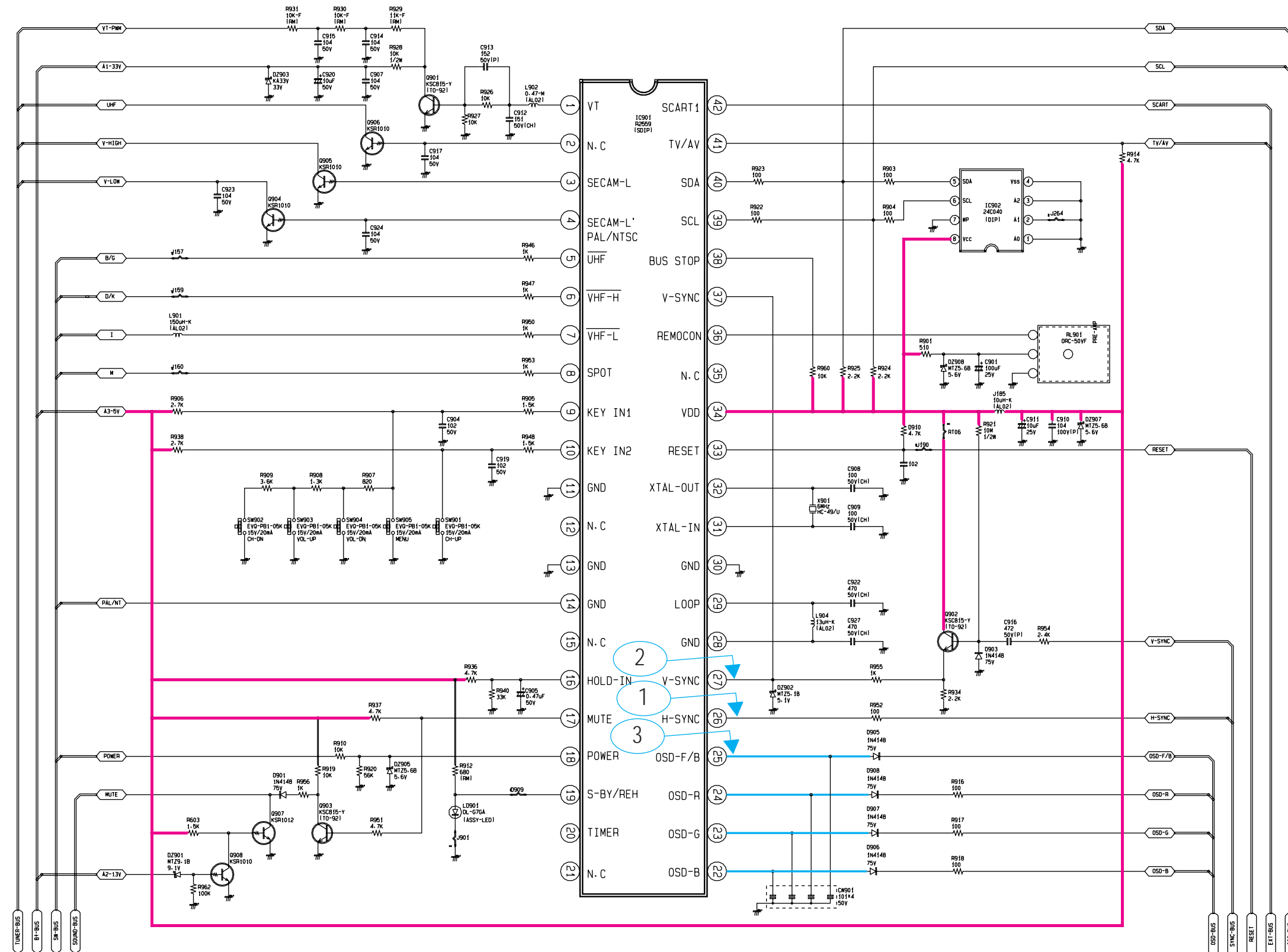

— : Power Line
 — : Signal Line

4. Alignment and Adjustments

4-1 Preadjustment

4-1-1 Factory Mode

1. Do not attempt these adjustments in the Video Mode.
2. The Factory Mode adjustments are necessary when either the EEPROM (IC902) or the CRT is replaced.
3. Do not tamper with the "Adjustment" screen of the Factory Mode menu. This screen is intended only for factory use.

4-1-2 When EEPROM (IC902) Is Replaced

1. When IC902 is replaced all adjustment data revert to initial values. It is necessary to re-program this data.
2. After IC902 is replaced, warm up the TV for 10 seconds.

4-1-3 When CRT Is Replaced

1. Make the following adjustments AFTER setting up after setting up purity and convergence :
 - White Balance
 - Sub-Brightness
 - Vertical Center
 - Vertical Size
 - Horizontal Size
 - Fail Safe (This adjustment must be the last step).
2. If the EEPROM or CRT is replaced, set PVA to 45 (factory mode) and set SC as follows.
 - 14, 16 inch : 0
 - 20 inch : 10
 - 21 inch : 12

4-2 Factory/Service Mode

4-2-1 Procedure for the "Adjustment" Mode

1. This mode uses the standard remote control. The Service Mode is activated by entering the following remote-control sequence :
 - (1) SLEEP→FACTORY.
 - (2) STAND-BY→ DISPLAY→ P.STD→ MUTE →POWER ON.
2. The "SERVICE (FACTORY)" message will be displayed. The Service Mode has four components: Adjustment, Test Pattern, Option Bytes and Reset.
3. Access the Adjustment Mode by pressing the "VOLUME" keys (Up or Down). The adjustment parameters are listed in the accompanying table, and selected by pressing the CHANNEL keys (▲, ▼).
4. Selection sequences for the all system:
 - DOWN or UP key:
 - AGC>VCO>SBT>SCT>SCR>SC>RG>GG>BG>CDL>BLU>PSL>PVS>PVA>PHS>NSR>STT
5. The VOLUME keys increase or decrease the adjustment values (stored in the non-volatile memory) when Adjustment Mode is cancelled.
6. Cancel the Adjustment Mode by re-pressing the "FACTORY" or "Power OFF" keys.

4-2-2 Main Adjustment Parameter

Table 4-1 Main Adjustment Parameter (Zilog, Philips μ -com)				
FUNCTION	OSD ABBREVIATION	RANGE	INITIAL DATA	REMARK
AUTO GAIN CONTROL	AGC	0 ~ 63 STEP	10	TDA8842 TDA8841
VOLTAGE CONTROL OSCILLATOR	VCO	0 ~ 128 STEP	80	
		0 ~ 1 STEP	1 (For East Europe)	
SUB BRIGHT	SBT	0 ~ 23 STEP	8	
SUB CONTRAST	SCT	0 ~ 23 STEP	10	
SUB COLOR	SCR	0 ~ 23 STEP	10	
S-CORRECTION	SC	0 ~ 63 STEP	12	
RED DRIVE GAIN	RG	0 ~ 63 STEP	47	
GREEN DRIVE GAIN	GG	0 ~ 63 STEP	32	
BLUE DRIVE GAIN	BG	0 ~ 63 STEP	34	
CATHODE DRIVE LEVEL	CDL	0 ~ 7 STEP	4	
BLUE STRETCH MODE	BLU	0 ~ 3 STEP	0	
PAL VERTICAL SLOPE	PSL	0 ~ 63 STEP	32	
PAL VERTICAL SHIFT	PVS	0 ~ 63 STEP	32	
PAL VERTICAL AMPLITUDE	PVA	0 ~ 63 STEP	42	
PAL HORIZONTAL SHIFT	PHS	0 ~ 63 STEP	40	
NTSC SUB COLOR	NSR	0 ~ 23 STEP	7	
SUB TINT	STT	1 ~ 13 STEP	0	
TTX SUB-CONTRAST	TSS	0 ~ 63 STEP	16 (Only TTX Model)	

NOTE : PVS,PVA, PHS, parameters must be aligned using the 50Hz vertical-field rates.

4-2-3 Test Pattern (Aging Mode)

1. This mode can be used during servicing, or for confirming that the convergence and purity adjustments are correct.
2. Access the Test Pattern parameters by pressing a CHANNEL keys (▲, ▼) while the Service Mode is on. The cursor will move to the test pattern. Press the VOLUME keys. On-screen display:

• WHITE — NON -TTX MICOM ONLY

• AGING — TTX MICOM

3. AGING Mode (Reference Only)

This pattern is used for pre-heating the CRT during manufacturing —it is accessed in the factory by twice pressing the “SLEEP → FACTORY→FACTORY” key, then white pattern will be displayed.

Even if the TV power is cut off, the Aging Mode is not cancelled, The aging mode is cancelled by repressing the “FACTORY” key or pressing the local “CH UP/DOWN” keys.

4-2-4 Option Bytes

In the Service Mode, various can be selected via the Option Bytes (8 bits each). Example:

SYSTEM OSD DISPLAY		BIT 6	BIT 5	BIT 4	BIT 3	BIT 2	BIT 1	BIT 0
BYTE 0 : 8	-			L (BIT : 0)	H (BIT : 8)	L (BIT : 0)	L (BIT : 0)	L (BIT : 0)
BYTE 1 : 0	-	L (BIT : 0)	L (BIT : 0)	L (BIT : 0)	L (BIT : 0)	L (BIT : 0)	L (BIT : 0)	L (BIT : 0)

TDA8842, CK SYSTEM, RCA JACK SYSTEM OSD DISPLAY

BYTE 0 : 11	—————	L (BIT : 1)	H (BIT : 0)	L (BIT : 0)	H (BIT : 0)	L (BIT : 1)
-------------	-------	-------------	-------------	-------------	-------------	-------------

4-2-4 (B) NON-TTX MICOM (SZM-173EW/EE) OPTION BYTE (FOR EUROPE)

	Destination	BYTE 0	BYTE 1
MP OPTION BYTE	United Kingdom	C3	98
	France/Swiss	45	9A
	Western Europe (except UK)	45	98
	Eastern Europe	41	58
	Ireland (CII)	43	98

BYTE	BIT	LOW(0)	HIGH(1)	Remark		
B Y T E 0	D7	3 BAND		UHF ONLY	HIGH (UK only)	
	D6	TV : NORMAL → ZOOM A/ : NORMAL → ZOOM	TV : NORMAL → ZOOM → 16:9 A/V : NORMAL → ZOOM		MUST = HIGH	
	D5	MUST LOW			POLAND OPTION - R 913 : 680Ω added - J901 : delete	
	D4	CH Up/down functional in the A/V Mode (SCART Jack)	CH Up/down not functional in the A/V Mode (RCA Jack)		MUST = LOW	
	D3	NOT USED			MUST = LOW	
	D 2	D2	D1	SOUND SYSTEM	COLOR SYSTEM	Destination
		0	0	"?" → B/G ↔ D/K : CK MODEL	AUTO : NO OSD	Eastern Europe/France/Swiss
		0	1	I ONLY (NO OSD) : CI,CII MDL		United Kingdom
		1	0	B/G ONLY (NO OSD) : CB,CX MDL		Western Europe
	1	1	NOT USED			
D0	TDA8374A		TDA8842	IC201 (ONE-CHIP) OPTION		
B Y T E 1	D7		English/German/Dutch/Italian/Spanish/Swedish/Croatian/Yugo/Greek/French		Western Europe (SZM-173EW/EW1)	
	D6		English/Romanian/Hungarian/Polish/Czech/Bulgarian		Eastern Europe (SZM-173EE)	
	D5	AFT ON (always)		AFT OFF (after fine tuning)		MUST = LOW
	D4	Existing sharpness level : TDA6108		Sharpness level up : TDA6107Q		MUST = HIGH
	D3	No Auto Power On		Auto Power On		MUST = HIGH
	D2	NTSC : 25 KHz (NTSC TABLE) PAL : 50 KHz (PAL TABLE)		NTSC : 25KHz(NTSC TABLE) PAL : 27KHz(NTSC TABLE)		
	D1	PAL / SECAM		SECAM - L		- France/Swiss (only) : HIGH
	D0	MUST : LOW				

● P-STD Classification (CON./BRI./SHAR./COL)

STANDARD MODE	DYNAMIC MODE	MOVIE MODE	MILD MODE	CUSTOM MODE
90/50/50/50	100/50/75/50	90/50/75/50	60/50/50/50	90/50/50/50

- Function Required: 1. PICTURE OFF (after 15 minutes) during no signal. 2. AUDIO MUTE during no signal.
- 3. No BLUE SCREEN during no RF signal (Blue Screen during AV).
- 4. No TIMER. 5. No CHILD LOCK. 6. See "Detailed functions of CF".

4-2-4 C) NON-TTX MICOM (SZM-173ER) OPTION BYTE (FOR RUSSIA)

Destination	BYTE 0	BYTE 1	Remark
Russia,CIS	49	58	Scart - 21 pin
Russia	59	58	Rca - 4 pin
Australia	5D	18	
India (CB MONO MODEL)	5D	38	

BYTE	BIT	LOW(0)	HIGH(1)	Remark		
B Y T E 0	D7			MUST = LOW		
	D6	TV : NORMAL → ZOOM A/V : NORMAL → ZOOM	TV : NORMAL → ZOOM → 16:9 A/V : NORMAL → ZOOM	MUST = HIGH		
	D5			MUST = LOW		
	D4	CH Up/down functional in the A/V Mode (SCART Jack)	CH Up/down not functional in the A/V Model (RCA Jack)			
	D3	PAL-I Used	PAL-I Not Used	MUST = HIGH		
	D 2	D2	SOUND SYSTEM		COLOR SYSTEM	
			0	0	"?" → B/G ↔ D/K : CK MODEL	AUTO : NO OSD
		D 1	0	1	I ONLY (NO OSD) : CI,CII MDL	
			1	0	B/G ONLY (NO OSD) : CB,CX MDL	
		1	1	NOT USED		
D0	TDA8374A	TDA8842	IC201 (ONE-CHIP) OPTION			
B Y T E 1	D7			MUST = LOW		
	D6	English	English/Russian			
	D5	AFT ON (always)	AFT OFF (after fine tuning)	BASIC = LOW (India HIGH)		
	D4	Existing sharpness level (when using the TDA6108 RGB AMP)	Sharpness level up (when using the TDA6107Q AMP)	MUST = HIGH		
	D3	No Auto Power On	Auto Power On	BASIC = HIGH		
	D2	NTSC: 25 KHz (NTSC TABLE) PAL : 50 KHz (PAL TABLE)	NTSC : 25 KHz (NTSC TABLE) PAL : 27 KHz (NTSC TABLE)			
	D1	NOT USED (MUST = LOW)				
	D0					

● P-STD Classification (CON/BR/SHAR/COL)

STANDARD MODE	DYNAMIC MODE	MOVIE MODE	MILD MODE	CUSTOM MODE
90/50/50/50	100/50/75/50	90/50/75/50	60/50/50/50	90/50/50/50

- Function Required : 1. PICTURE OFF (after 15 minutes) during no signal
- 2. AUDIO MUTE during no signal
- 3. BLUE SCREEN available
- 4. TIMER available
- 5. No CHILD LOCK

4-2-4 (D) NON-TTX MICOM (SZM-173AR/EA) OPTION BYTE (FOR MIDDLE EAST/AFRICA)

		Destination		BYTE 0	BYTE 1
MP OPTION BYTE		Middle East (EA or AR)		7F	58
		Africa (EA)		67	D8
		GAME (Middle East)		7F	5A

BYTE	BIT	LOW (0)	HIGH (1)	Remark		
B Y T E 0	D7			MUST = LOW		
	D6	TV : NORMAL → ZOOM A/V : NORMAL → ZOOM	TV : NORMAL → ZOOM → 16:9 A/V : NORMAL → ZOOM	MUST = HIGH		
	D5	NOT USED	CHILD LOCK ON	MUST = HIGH		
	D4	CH Up/down functional in the A/V Mode (SCART Jack)	CH Up/down not functional in the A/V Model (RCA Jack)	Middle East : HIGH Africa : LOW		
	D3	Sound-I System Used	Sound-I System Not Used			
	D 2	D2	D2	COLOR SYSTEM		SOUND SYSTEM
			D1	● CK : AUTO (NO OSD)		"?" → B/G → D/K
		D1	D2	● CW : -. RF : AUTO → PAL → SECAM → NT4.43 -. A/V : AUTO → PAL → SECAM → NT4.43 → NT3.58		"?" → B/G → D/K → I
			D1	● CB : -. RF : PAL ONLY -. A/V : AUTO → PAL → NT4.43 → NT3.58		B/G ONLY (NO OSD)
	D 1	D2	● CS : -. RF : AUTO → PAL → SECAM → NT4.43 → NT3.58 -. A/V : AUTO → PAL → SECAM → NT4.43 → NT3.58		"?" → B/G → D/K → I → NT-M →	
D1						
D0		TDA8374A	TDA8842	IC201 (ONE-CHIP) OPTION		

B Y T E 1	BIT	LANGUAGE		Remark	
		D7	D6		
D7	D7	D6			
		0	0	-	NOT USED
		0	1	ENG / ARAB	Middle East
		1	0	-	NOT USED
D6	D6	D7			
		1	1	ENG / ARAB / FRENCH	EA VERSION (Africa ONLY)
D5		AFT ON (always)	AFT OFF after fine tuning	MUST = LOW	
D4		Existing sharpness level (when using the TDA6108 RGB AMP)	Sharpness level up (when using the TDA6107Q RGB AMP)	MUST = HIGH	
D3		No Auto Power On	Auto Power On	MUST = HIGH	
D2		NTSC : 25 KHz (NTSC TABLE) PAL : 50 KHz (PAL TABLE)	NTSC : 25 KHz (NTSC TABLE) PAL : 27 KHz (NTSC TABLE)		
D1		Others	GAME		
D0		MUST = LOW			

- Function Required : 1. PICTURE OFF (after 15 minutes) during no signal
- 2. AUDIO MUTE during no signal.
- 3. BLUE SCREEN ON/OFF
- 4. TIMER (CLOCK ON/OFF)
- 5. CHILD LOCK ON (always)

4-2-4 (E) NON-TTX MICOM (SZM-173EV/ET) OPTION BYTE (FOR ASIA)

	DESTINATION	LINE-STREEO		MONO(TV-OUT)		MONO(MONO-OUT)	
		BYTE 0	BYTE 1	BYTE 0	BYTE 1	BYTE 0	BYTE 1
OPTION - BYTE	Vietnam / Malaysia	DF	D8	5F	58	5F	D8
	Indonesia (CB MODEL CLOCK ON)	DD	DA	5D	5A	5D	DA
	Thailand (CB MODEL)	-		5D	58	5D	D8
	India (CB MODEL AFT OFF)	DD	B8	-	-	-	-
	India (CS MODEL AFT OFF)	DF	B8	5F	38	5F	B8

BYTE	BIT	LOW (0)	HIGH (1)	Remark	
B Y T E 0	D7	LINE STEREO OFF	LINE STEREO ON	SZM-173EV (only)	
	D6	TV : NORMAL → ZOOM A/V : NORMAL → ZOOM	TV : NORMAL → ZOOM → 16:9 A/V : NORMAL → ZOOM	MUST = HIGH	
	D5			MUST = LOW	
	D4	CH Up/down functional in the A/V Mode (SCART Jack)	CH Up/down not functional in the A/V Mode (RCA Jack)	BASIC = HIGH	
	D3	Sound-I System Used	Sound-I System Not Used		
	D2	D2	COLOR SYSTEM		SOUND SYSTEM
		D1	Destination		
		0	0	● CK : AUTO (NO OSD)	"?" → B/G → D/K
		0	1	● CW : - RF : AUTO → PAL → SECAM → NT4.43 - A/V : AUTO → PAL → SECAM → NT4.43 → NT3.58	"?" → B/G → D/K → I
	D1	1	0	● CB : - RF : PAL ONLY - A/V : AUTO → PAL → NT4.43 → NT3.58	B/G ONLY (NO OSD) Indonesia/Thailand/ India
1		1	● CS : - RF : AUTO → PAL → SECAM → NT4.43 → NT3.58 - A/V : AUTO → PAL → SECAM → NT4.43 → NT3.58	"?" → B/G → D/K → I Vietnam Malaysia	
D0	TDA8374A		TDA8842	IC201 (ONE-CHIP) OPTION	
B Y T E 1	D7	TV OUT	MONITOR OUT		
	D6	English ONLY	English/Vietnamese/Indonesian/Malay	SZM-173EV	
			English/Thai	SZM-173ET	
	D5	AFT ON (always)	AFT OFF (after fine tuning)		
	D4	Existing sharpness level (when using the TDA6108 RGB AMP)	Sharpness level up (when using the TDA6107Q RGB AMP)	MUST = HIGH	
	D3	No Auto Power On	Auto Power On	BASIC = HIGH	
	D2	NTSC : 25KHz (NTSC TABLE) PAL : 50KHz (PAL TABLE)	NTSC : 25KHz (NTSC TABLE) PAL : 27KHz (PAL TABLE)	MUST = LOW	
	D1	CLOCK DISPLAY OFF	CLOCK DISPLAY ON	Indonesia ONLY : HIGH	
D0	MUST = LOW				

- Function Required : 1. PICTURE OFF (after 15 minutes) during no signal. 2. AUDIO MUTE during no signal. 3. BLUE SCREEN ON/OFF. 4. TIMER (CLOCK ON/OFF). 5. No CHILD LOCK

SZM -173ET (16K) : Z90203 → WITHOUT LINE STEREO
 SZM -173EV (24K) : Z90234 → WITH LINE STEREO

4-2-4 (F) TTX MICOM (SZM-175EA/EP) OPTION BYTE (FOR MIDDLE EAST ASIA)

MP OPTION BYTE	Destination	Application MICOM	BYTE0	BYTE1
	Iran (Persian TTX)	SPM-175EP	1F	1B
	Middle East (except Iran)	SPM-175EA	1F	1B
	Africa		07	1B
	Singapore		17	1B
Australia / Newzealand		1D	18	

BYTE	BIT	LOW (0)	HIGH (1)	Application MICOM		
B Y T E 0	D7	NOT USED		ALL = LOW		
	D6	TV : NORMAL → ZOOM → 16:9 A/V : NORMAL → ZOOM	TV : NORMAL → ZOOM → 16:9 A/V : NORMAL → ZOOM → 16:9	MUST = LOW		
	D5	NOT USED		ALL = LOW		
	D4	CH Up/down functional in the A/V Mode (SCART Jack)	CH Up/down not functional in the A/V Mode (RCA Jack)	- Africa : SCART - Others : RCA		
	D3	Sound-I System Used	Sound-I System Not Used			
	D2	D2	COLOR SYSTEM		SOUND SYSTEM	
		D1	COLOR SYSTEM		Remark	
		D0	COLOR SYSTEM		Remark	
		D0	COLOR SYSTEM		Remark	
	D0	TDA8374A		TDA 8842		
B Y T E 1	D7	NOT USED		ALL (FIX = LOW)		
	D6	NOT USED				
	D5	NOT USED				
	D4	Existing sharpness level (when using the TDA6108 RGB AMP)	Sharpness level up (when using the TDA6107Q RGB AMP)	ALL (BASIC = HIGH) → TEST Unnecessary		
	D3	No Auto Power On	Auto Power On	ALL (BASIC = HIGH)		
	D2	NTSC : 25 KHz (NTSC TABLE) PAL : 50 KHz (PAL TABLE)	NTSC : 25 KHz (NTSC TABLE) PAL : 27 KHz (NTSC TABLE)			
	D1	D1 D0	00	01	10	11
D0		B/G	D/K	I	?	

● OSD language by micom

1. Persian (for Iran) : SPM-175EP : English/Persian (Iranian)
2. Arab (Middle East, Africa) : SPM-175EA : English/French/Arabian

- Function Required :
- | | |
|--|------------------|
| 1. PICTURE OFF (after 15 minutes) during no signal | 4. No TIMER |
| 2. AUDIO MUTE (during no signal) | 5. No CHILD LOCK |
| 3. No BLUE SCREEN | |

4-2-4 (G) TTX MICOM (SPM-175EE/ER/EG/EU) OPTION BYTE (FOR EUROPE)

	Destination	Application MICOM	BYTE 0	BYTE 1	LANGUAGE
MP OPTION BYTE	United Kingdom (CI)	SPM-175EE	83	18	See BYTE 1 D5
	Other Western Europe (CB)		05	18	
	Eastern Europe (CK)		01	38	
	Ireland (CII)		03	18	
	France/Swiss	SPM-175EU	05	58	
	Yugo/Greece	SPM-175EG	05	18	English/Yugo/Greek
	Russia/Bulgaria	SPM-175ER	01	19	English/Russian/Bulgarian
	Russia		11	19	Russian (Rca - 4pin)

BYTE	BIT	LOW(0)	HIGH(1)	Remark	
B Y T E 0	D7	3 BAND	UHF DONLY (UK only)		
	D6	TV : NORMAL → ZOOM → 16:9 A/V : NORMAL → ZOOM	TV : NORMAL → ZOOM → 16:9 A/V : NORMAL → ZOOM → 16:9		
	D5	MUST = LOW	< POLAND OPTION > R 913 : 680Ω added. J901 : Delete		
	D4	CH Up/Down functional in the A/V Mode (SCART Jack)	CH Up/Down not functional in the A/V Model (RCA Jack)	MUST = LOW	
	D3	P-STD NORMAL	P-STD MAX	MUST = LOW	
	D2	D2	SOUND SYSTEM		Remark No SOUND SYSTEM in the A/V Mode
		D1	COLOR SYSTEM		
		D0	AUTO (NO OSD)		
		D0	NOT USED		
	D1	D1	SOUND SYSTEM		Remark No SOUND SYSTEM in the A/V Mode
D0	COLOR SYSTEM				
D0	AUTO (NO OSD)				
D0	NOT USED				
D0	D0	TDA8374A	TDA8842		
B Y T E 1	D7	NOT USED		FIX = LOW	
	D6	PAL/SECAM	SECAM - L	HIGH (CF only)	
	D5	English/German/French/Dutch/ Italian/Spanish/Swedish	English/Croatian/Romanian/ Hungarian/Polish/Czech	This bit is only applied to SPM-175EE	
	D4	Existing sharpness level (when using the TDA6108 RGB AMP)	Sharpness level up (when using the TDA6107Q AMP)	ALL BASIC = HIGH → TEST Unnecessary	
	D3	No Auto Power On	Auto Power On	ALL BASIC = HIGH	
	D2	NTSC : 25KHz (NTSC TABLE) PAL : 50KHz (PAL TABLE)	NTSC : 25KHz (NTSC TABLE) PAL : 27KHz (NTSC TABLE)	ALL (RF VOL. CURVE) BASIC = LOW	
	D1	MUST = LOW			
	D0	B/G	D/K	175ER is only applied (Others = LOW)	

● P-STD Classification (CON/BRI/SHRP/COL)

D3 BIT	STANDARD MODE	DYNAMIC MODE	MOVIE MODE	MILD MODE	CUSTOM MODE
0	90/50/50/50	100/50/50/50	75/55/50/50	60/50/50/50	90/55/25/50

- Function Required :1. PICTURE OFF (after 15 minutes) during no signal. 2. AUDIO MUTE (during no signal).
3. No BLUE SCREEN. 4. No TIMER (CLOCK /OFF). 5. No CHILD LOCK

4-2-5 RESET

The Reset Mode is used during factory inspection.
Function Reset:

1. Channels	Add/Erase
2. Sort	Non
3. System	Auto
4. Timer	off
5. Blue Screen	off
6. Child Lock	off
7. Picture	standard
8. Volume	10
9. CH. Skip	Erased

4-3 Other Adjustments

4-3-1 General

1. Usually, a color TV needs only slight touch-up adjustment upon installation. Check the basic characteristics such as height, horizontal and vertical sync and focus.
2. The picture should have good black and white details. There should be no objectionable color shading; if color shading is present, perform the purity and convergence adjustments described below.
3. Use the specified test equipment or its equivalent.
4. Correct impedance matching is essential.
5. Avoid overload. Excessive signal from a sweep generator might overload the front-end of the TV. When inserting signal markers, do not allow the marker generator to distort test results.
6. Connect the TV only to an AC power source with voltage and frequency as specified on the backcover nameplate.
7. Do not attempt to connect or disconnect any wires while the TV is turned on. Make sure that the power cord is disconnected before replacing any parts.
8. To protect against shock hazard, use an isolation transformer.

4-3-2 Automatic Degaussing

A degaussing coil is mounted around the picture tube, so that external degaussing after moving the TV should be unnecessary. But the receiver must be properly degaussed upon installation.

The degaussing coil operates for about 1 second after the power is switched ON. If the set has been moved or turned in a different direction, disconnect its AC power for at least 30 minutes.

If the chassis or parts of the cabinet become magnetized, poor color purity will result. If this happens, use an external degaussing coil. Slowly move the degaussing coil around the faceplate of the picture tube and the sides and front of the receiver. Slowly withdraw the coil to a distance of about 6 feet before removing power.

4-3-3 High Voltage Check

CAUTION: There is no high voltage adjustment on this chassis. The B+ power supply must be set to +125 volts (Full color bar input and normal picture level).

1. Connect a digital voltmeter to the second anode of the picture tube.
2. Turn on the TV. Set the Brightness and Contrast controls to minimum (zero beam current).
3. The high voltage should not exceed 27.5KV.
4. Adjust the Brightness and contrast controls to both extremes. Ensure that the high voltage does not exceed 27.5KV under any conditions.

4-3-4 FOCUS Adjustment

1. Input a black and white signal.
2. Adjust the tuning control for the clearest picture.
3. Adjust the FOCUS control for well defined scanning lines in the center area of the screen.

4-3-5 Cathode Voltage Adjustment (Screen Adjustment)

1. Connect CRT socket pin GK to an oscilloscope probe.
2. Input a gray scale pattern. (Use a pattern generator, PM5518)
3. Use the P mode key (on the remote control) for the STANDARD picture.
4. Adjust the Screen VR (on the FBT) so that the voltage on the oscilloscope becomes $130 \pm 2.5V$ (See Fig. 4-1).

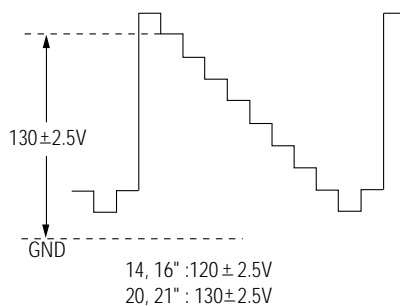

Fig. 4-1

4-3-6 Purity Adjustment

1. Warm up the receiver for at least 20 minutes.
2. Plug in the CRT deflection yoke and tighten the clamp screw.
3. Plug the convergence yoke into the CRT and set in as shown in Fig. 4-2.
4. Input a black and white signal.
5. Fully demagnetize the receiver by applying an external degaussing coil.
6. Turn the CONTRAST and BRIGHTNESS controls to maximum.
7. Loosen the clamp screw holding the yoke. Slide the yoke backward or forward to provide vertical green belt. (Fig. 4-3).
8. Tighten the convergence yoke.
9. Slowly move the deflection yoke forward, and adjust for the best overall green screen.
10. Temporarily tighten the deflection yoke.
11. Produce blue and red rasters by adjusting the low-light controls. Check for good purity in each field.
12. Tighten the deflection yoke.

4-3-8 Center Convergence Adjustment

1. Warm up the receiver for at least 20 minutes.
2. Adjust the two tabs of the 4 pole magnets to change the angle between them. Superimpose the red and blue vertical lines in the center area of the screen.
3. Adjust the Brightness and Contrast controls for a well defined picture.
4. Adjust the two-tab pairs of the 4 pole magnets, and change the angle between them. Superimpose the red and the blue vertical lines in the center area of the screen.
5. Turn the both tabs at the same time, keeping the angle constant, and superimpose the red and blue horizontal line in the center of the screen.
6. Adjust the two-tab pairs of the 6-pole magnets to superimpose the red and blue line onto the green. (Changing the angle affects the vertical lines, and rotating both magnets affects the horizontal lines.)
7. Repeat adjustments 2~6, if necessary.
8. Since the 4-pole magnets and 6-pole magnets interact, the dot movement is complex (Fig. 4-5).



Fig. 4-5 Center Convergence Adjustment

4-3-9 VCO Adjustment

Set the vco data to 80 (Factory Mode).

NOTE : For SZM-173EW and SPM-175E (Western Europe remote control), set the VCO data to 1.

4-3-10 RF AGC Adjustment

Set the AGC data to 14 (Factory Mode).

4-3-11 Sub-Color Adjustment

Set SCR data to 10 (Factory Mode).

4-3-12 Geometry Adjustment

SC → PVA → PVS → PSL → PHS

1. Input a lion head pattern (in the PAL channel).
2. Set the SC (S-Correction) as follows : 12 (21"), 10 (20"), 0 (14", 16") and PVA 40 so that the lion head circle becomes oval.
3. Adjust with PVS (Vertical shift) so that the top margin of the picture is 4.

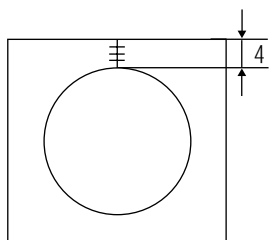

Fig. 4-7

4. Adjust with PSL (Vertical-Slope) so that the bottom margin of the picture is 4.

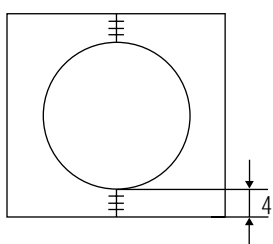

Fig. 4-8

5. Adjust with PHS (Horizontal Shift) so that the lion-head pattern and CRT centers are aligned.

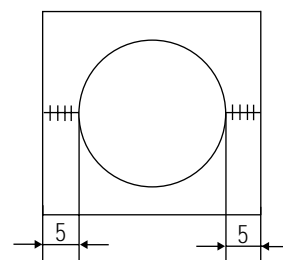

Fig. 4-9

6. Adjust PHS (using the width coil) so that the left and right margins of the picture are 5.